

# Monitoring and Controlling of Smart Equipments towards Manufacturing Industries using IoT

<sup>1</sup>Naveen N, <sup>2</sup>Lakshmi M A, <sup>3</sup>Gajendra M, <sup>4</sup>Naveen N

<sup>1,2,3,4</sup>Dept. of CSE, Government Polytechnic, Chintamani, Karnataka, India

## Abstract

Numerous corporations and start-up ventures have latched onto the Internet of Things concept looking to take advantage of whatever business opportunities are available. IoT assumes that the underlying network equipment and related technology can operate semi-intelligently and often automatically. Simply keeping mobile devices connected to the Internet can be difficult enough much less trying to make them smarter. People have diverse needs that require an IoT system to adapt or be configurable for many different situations and preferences. The “Monitoring and Controlling of Smart Equipment’s towards Manufacturing Industries using IoT” which is an Industrial automation projects keep you safe, manage energy consumption, and provide entertainment. Solutions for your industry or business are available for every income level and lifestyle. Simply choose the automation, energy management, and convenience features you desire. Industrial automation systems may be installed in new or existing structures and may be accessed and controlled via your smart phone or tablet. It is automation of the industrial, housework or household activity. Industrial automation may include centralized control of lighting, HVAC (heating, ventilation and air conditioning), appliances, security locks of gates and doors and other systems, to provide improved convenience, comfort, energy efficiency and security.

## Keywords

IoT, GSM, Wireless Networks, Microcontroller

## I. Introduction

The term Internet of Things (often abbreviated IoT) was coined more than ten years ago by industry researchers but has emerged into mainstream public view only more recently. Some claim the Internet of Things will completely transform how computer networks are used for the next 10 or 100 years, while others believe IoT is simply hype that won’t much impact the daily lives of most people.

Internet of Things represents a general concept for the ability of network devices to sense and collect data from the world around us, and then share that data across the Internet where it can be processed and utilized for various interesting purposes. Some also use the term industrial Internet interchangeably with IoT. This refers primarily to commercial applications of IoT technology in the world of manufacturing. The Internet of Things is not limited to industrial applications, however some future consumer applications envisioned for IoT.

Internet of Things immediately triggers questions around the privacy of personal data. Whether real-time information about our physical location, or updates about our weight and blood pressure that may be accessible by our health care providers, having new kinds and more detailed data about ourselves streaming over wireless networks and potentially around the world is an obvious concern. Supplying power to this new proliferation of IoT devices and their network connections can be expensive and logistically difficult. Although many mobile devices are optimized for lower

power usage, energy costs to keep potentially billions of them running remains high.

Numerous corporations and start-up ventures have latched onto the Internet of Things concept looking to take advantage of whatever business opportunities are available. IoT assumes that the underlying network equipment and related technology can operate semi-intelligently and often automatically. Simply keeping mobile devices connected to the Internet can be difficult enough much less trying to make them smarter. People have diverse needs that require an IoT system to adapt or be configurable for many different situations and preferences.

Industrial automation projects keep you safe, manage energy consumption, and provide entertainment. Solutions for your industry or business are available for every income level and lifestyle. Simply choose the automation, energy management, and convenience features you desire. Industrial automation systems may be installed in new or existing structures and may be accessed and controlled via your smart phone or tablet. It is automation of the industrial, housework or household activity. Industrial automation may include centralized control of lighting, HVAC (heating, ventilation and air conditioning), appliances, security locks of gates and doors and other systems, to provide improved convenience, comfort, energy efficiency and security.

Industrial automation for the elderly and disabled can provide increased quality of life for persons who might otherwise require caregivers or institutional care. This project helps to avoid the wastage of energy, here you can control some of your industrial appliances through internet that can switch ON/OFF some of home appliances like water heater, lights and fans etc. Automation used at the industry or home is no longer a future found in state-of-the-art buildings but it is getting more common as the prices fall to reasonable ranges.

Industrial automation is the residential extension of building automation and designed a novel gateway between industrial appliance connected to a smart phone and the Internet mainly for the scenario in industries and building automation. With the improvement of the traditional gateway, the users on the Internet can control the sensors which are connected to a PC with internet.

The popularity of industrial automation has been increasing greatly in recent years due to much higher affordability and simplicity through Smartphone and tablet connectivity. The concept of the “Internet of Things” has tied in closely with the popularization of home automation.

## II. Need for the System

An industrial automation system integrates electrical devices in a industries and the devices may be connected through a computer or a smart phone through GSM. GSM (Global System for Mobile communication) is a digital mobile telephony system that is widely

used in Europe and other parts of the world. GSM uses a variation of time division multiple access and digitizes and compresses data, then sends it down a channel with two other streams of user data, each in its own time slot.

Since many GSM network operators have roaming agreements with foreign operators, users can often continue to use their mobile phones when they travel to other countries. SIM cards (Subscriber Identity Module) holding home network access configurations may be switched to those will metered local access, significantly reducing roaming costs while experiencing no reductions in service.

This technology is used to control the industrial appliance like fans, lights and water heater, buzzer, AC motors in an industry which are connected to the microcontroller AT89S52 and this microcontroller will be connected to the PC or Mobile device with Android Support which has Internet, from anywhere we can easily switch ON or switch OFF the device, then it will avoid the wastage of energy.

The GSM Modem is having internal TCP/IP stack to enable you to connect with internet via GPRS. It is suitable for SMS, Voice as well as data transfer application in M2M interface. The onboard Regulated Power supply allows you to connect wide range unregulated power supply. Using GSM modem, you can make audio calls, SMS, Read SMS, attend the incoming calls and internet through simple AT commands.

The devices such as motors, generators, power plant, buzzer to allow control by a personal computer, and may allow remote access from the internet. Through the integration of information technologies with the home environment, systems and appliances are able to communicate in an integrated manner which results in convenience, energy efficiency, and safety benefits.

### A. Objective of the Project

This project concentrates mainly on monitoring and controlling smart equipment's using GSM module from the perspective of internet of things and sensing the remote temperature using temperature sensor and detecting of gas through the gas sensor and these will be processed by the microcontroller, The data is then send to the GSM Modem through serial port using Max232. On the other side, another GSM modem receives message and sends to personal computer. Finally analyses the data in centre server, give the accurate response after knowing the working status of local device. The system is safe, economic, high precision and real time and worth promoting.

In this technology mainly we are using the Internet of things; The Internet of Things (IOT) refers to uniquely identifiable objects and their virtual representations in an Internet-like structure. The concept of the Internet of Things first became popular when it includes a billion of devices in future If all objects and people in daily life were equipped with identifiers, they could be managed and inventoried by smart phone.

### III. Related Works

#### A. Remote Controller

It provides simple wireless controls, automation and telemetry in a wide variety of industrial applications, including automated pump controls, wireless tactical airfield lighting and remote temperature monitoring. Anything that can be switched (eg: ON or OFF) or

that can send and receive data can be done so wirelessly.

Remote control Technology is a global leader in a Wireless solutions industry, providing unique, application focused Engineering and Systems integration capabilities. It has designed, manufactured and supplied both custom and off-the-shelf product and services. It can be classified into wired and wireless remote controller

#### Wired

It is a component of an electronic device such as TV set, DVD Player or other home appliances. They are consumer IR devices which send digitally-coded pulses of infrared radiation to control functions such as power, volume, tuning, temperature set point, fan and other features.

#### Disadvantages

- Disturbing Cable with the danger to get caught.
- Only shorter operation with the charged accumulator.

#### Wireless

- A device used to control the operations of a machine, as a television set, from a distance.

#### Disadvantages

- Control via the infrared remote control.
- More difficult to operate vat larger dimensions of the transport load.

#### B. Bluetooth

Bluetooth is a wireless technology standard for exchanging data over short distances (using short-wavelength UHF radio waves in the ISM band from 2.4 to 2.485 GHz) from fixed and mobile devices, and building personal area networks (PANs). Invented by telecom vendor Ericsson in 1994, it was originally conceived as a wireless alternative to RS-232 data cables. It can connect several devices, overcoming problems of synchronization.

Bluetooth is managed by the Bluetooth Special Interest Group (SIG), which has more than 25,000 member companies in the areas of telecommunication, computing, networking, and consumer electronics. The IEEE standardized Bluetooth as IEEE 802.15.1, but no longer maintains the standard.

Bluetooth operates at frequencies between 2402 and 2480 MHz, or 2400 and 2483.5 MHz including guard bands 2 MHz wide at the bottom end and 3.5 MHz wide at the top. Bluetooth uses a radio technology called frequency-hopping spread spectrum. Bluetooth divides transmitted data into packets, and transmits each packet on one of 79 designated Bluetooth channels. Each channel has a bandwidth of 1 MHz. It usually performs 800 hops per second.

#### C. Wi-Fi

Wi-Fi is a technology that allows electronic devices to connect to a wireless LAN (WLAN) network, mainly using the 2.4 gigahertz (12 cm) UHF and 5 gigahertz (6 cm) SHF ISM radio bands. A WLAN is usually password protected, but may be open, which allows any device within its range to access the resources of the WLAN network.

#### D. Zig-Bee

ZigBee is an IEEE 802.15.4 – based specification for a suite of high-level communication protocol used to create personal area network with small, low power digital radio. Its low power consumption limits transmission distance to 10-100 meters line-of-sight.

**IV. Methodology**

**A. GSM**

GSM, which stands for Global System for Mobile communications, reigns (important) as the world’s most widely used cell phone technology. Cell phones use a cell phone service carrier’s GSM network by searching for cell phone towers in the nearby area. Global system for mobile communication (GSM) is a globally accepted standard for digital cellular communication.

GSM is the name of a standardization group established in 1982 to create a common European mobile telephone standard that would formulate specifications for a pan-European mobile cellular radio system operating at 900 MHz. It is estimated that many countries outside of Europe will join the GSM partnership.

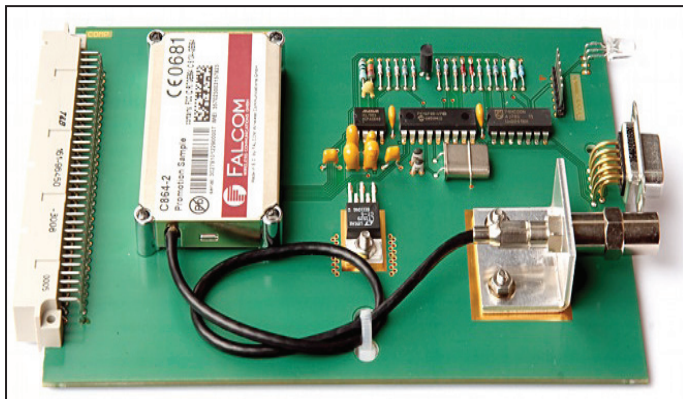

Fig. 1: GSM Modem

Advantage of using this modem will be that you can use its RS232 port to communicate and develop embedded applications. Applications like SMS control, data transfer, remote control and logging can be developed easily. The modem can be connected to any microcontroller through MAX232 can be used to send and receive SMS or make/receive voice calls. It can be used in GPRS mode to connect to internet. GSM modem is a highly flexible plug and play quad band SIM900A GSM modem for direct and easy integration to RS232 applications.

**System Architecture**

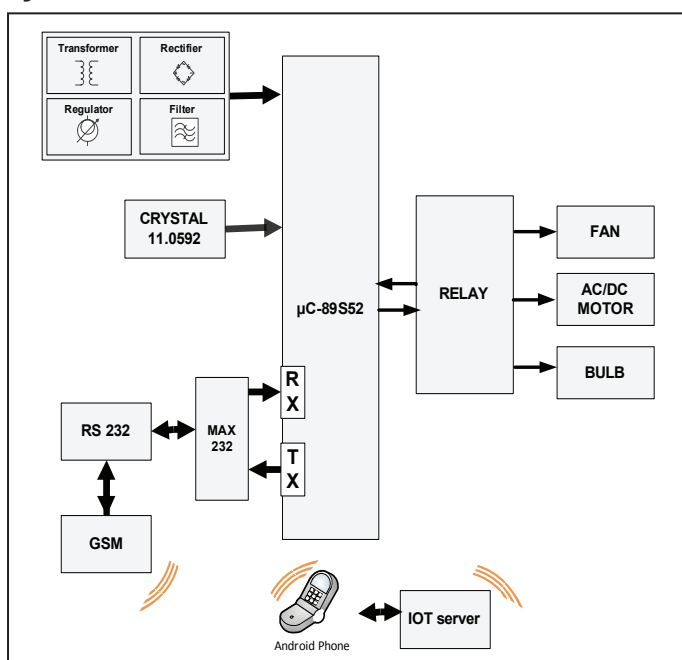

Fig. 2: System Architecture

**A. Microcontroller AT89S52**

A microcontroller is a single chip that contains the processor (the CPU), non-volatile memory for the program (ROM or flash), volatile memory for input and output (RAM), a clock and an I/O control unit. Also called a “computer on a chip,” billions of microcontroller units (MCUs) are embedded each year in a myriad of products from toys to appliances to automobiles. An integrated circuit that contains many of the same items that a desktop computer has, such as CPU, memory, etc., but does not include any “human interface” devices like a monitor, keyboard, or mouse. Microcontrollers are designed for machine control applications, rather than human interaction.

**B. PCB**

Printed Circuit Board is complex electronic circuits require many electrical connections between components. A printed circuit board is simply a rigid piece of (usually) fiberglass that has many copper wires embedded on (or sometimes in) it. These wires carry the signals between individual components in the circuit. Any microcontroller (or computer) system consists of two primary components: hardware and software. The hardware is the actual physical components of the system. The software is a list of instructions which reside inside the hardware. We will now create the hardware, and then write a software program to “control it”.

In order for our microcontroller to interact with the real world, we need to assemble some “hardware”. We’ll be using a PCB called the “Board of Education”. This board was created to simplify connecting “real world stuff” to the BASIC Stamp. Connectors are provided for power (wall transformer or 9 volt battery), the programming cable, and the Input / Output pins of the BASIC Stamp. There is also a “prototyping area” or breadboard (the white board with all the holes in it)

The AT89S52 is a low-power, high-performance CMOS 8-bit microcontroller with 8K bytes of in-system programmable Flash memory. It is compatible with the industry-standard 80C51 instruction set and pin out. The on-chip Flash allows the program memory to be reprogrammed in-system or by a conventional nonvolatile memory programmers. By combining a versatile 8-bit CPU with in-system programmable Flash on a monolithic chip, the Atmel AT89S52 is a powerful microcontroller, which provides a highly flexible and cost-effective solution to many, embedded control applications.

**C. MAX 232**

The MAX232 is an integrated circuit first created in 1987 by Maxim Integrated Products that converts signals from a TIA-232 (RS-232) serial port to signals suitable for use in TTL-compatible digital logic circuits. The MAX232 is a dual driver/receiver and typically converts the RX, TX, CTS and RTS signals. The RS232 standard is not TTL compatible; therefore it requires a line driver such as MAX232 chip to convert RS232 voltage levels to TTL levels, and vice versa. The MAX232 is an integrated circuit that converts signals from an RS-232 serial port to signals suitable for use in TTL compatible digital logic circuits. The MAX232 is a dual driver/receiver and typically converts the RX, TX, CTS and RTS signals.

The drivers provide RS-232 voltage level outputs (approx. ± 7.5 V) from a single + 5 V supply via on-chip charge pumps and

external capacitors. This makes it useful for implementing RS-232 in devices that otherwise do not need any voltages outside the 0 V to + 5 V range, as power supply design does not need to be made more complicated just for driving the RS-232 in this case. The receivers reduce RS-232 inputs (which may be as high as ± 25 V), to standard 5 V TTL levels. These receivers have a typical threshold of 1.3 V, and a typical hysteresis of 0.5 V. The later MAX232A is backwards compatible with the original MAX232 but may operate at higher baud rates and can use smaller external capacitors – 0.1 μF in place of the 1.0 μF capacitors used with the original device. The newer MAX3232 is also backwards compatible, but operates at a broader voltage range, from 3 to 5.5V. Voltage levels It is helpful to understand what occurs to the voltage levels.

The MAX232(A) has two receivers that convert from RS-232 to TTL voltage levels, and two drivers that convert from TTL logic to RS-232 voltage levels. As a result, only two out of all RS-232 signals can be converted in each direction. Typically, the first driver/receiver pair of the MAX232 is used for TX and RX signals, and the second one for CTS and RTS signals. There are not enough drivers/receivers in the MAX232 to also connect the DTR, DSR, and DCD signals. Usually, these signals can be omitted when, for example, communicating with a PC's serial interface. If the DTE really requires these signals, either a second MAX232 is needed, or some other IC from the MAX232 family can be used. Also, it is possible to connect DTR (DE-9 pin #4) directly to DSR (DE-9 pin #6) without going through any circuitry, which provides an automatic (brain-dead) DSR acknowledgment of the incoming DTR signal.

**D. Relays Working**

All relays contain a sensing unit, the electric coil, which is powered by AC or DC current. When the applied current or voltage exceeds a threshold value, the coil activates the armature, which operates either to close the open contacts or to open the closed contacts. When a power is supplied to the coil, it generates a magnetic force that actuates the switch mechanism. The magnetic force is, in effect, relaying the action from one circuit to another. The first circuit is called the control circuit; the second is called the load circuit.

There are three basic functions of a relay: On/Off Control, Limit Control and Logic operations.

- **On/Off Control:** Example: Air conditioning control, used to limit and control a “high power” load, such as a compressor
- **Limit Control:** Example: Motor Speed Control, used to disconnect a motor if it runs slower or faster than the desired speed
- **Logic Operation:** Example: Test Equipment, used to connect the instrument to a number of testing points on the device under test

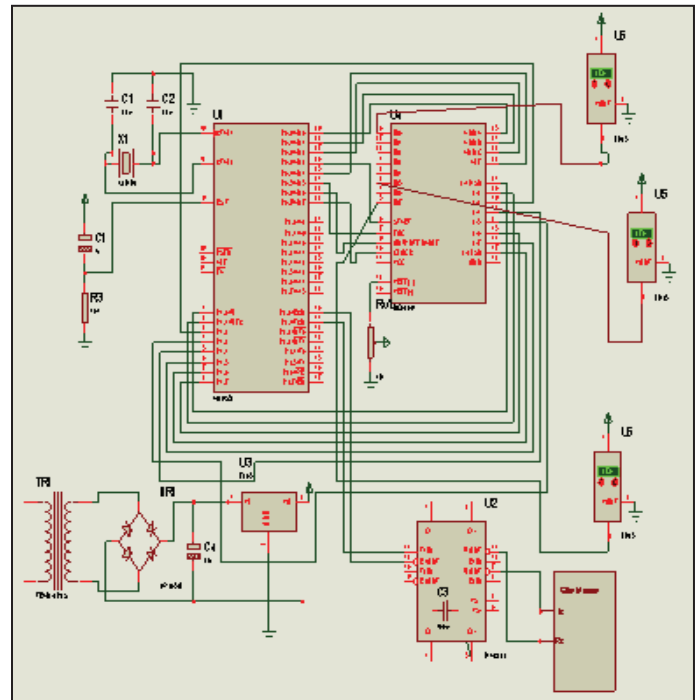

Fig. 3: Layout Diagram

**Dataflow Diagram**

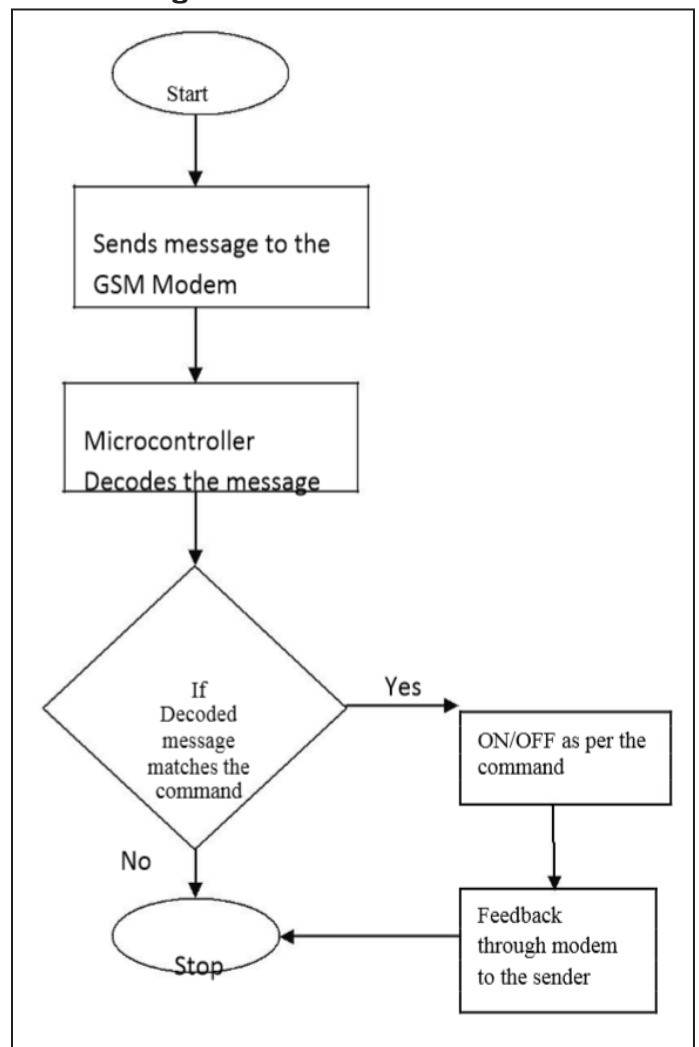

Fig. 4: Dataflow Diagram

GSM modem accepts any GSM network operator SIM card and can act just like a mobile number. Global System for Mobile

Communication which is a wireless modem used to communicate between controlling unit and android phone. It just accepts certain commands through a serial interface and acknowledges for those. These commands are called as AT commands.

### V. Conclusion and Future Scope

GSM based remote temperature Monitoring system is implemented, remote temperature is sensed and sent to the personal computer successfully using GSM modem. Using the equipment, temperature is successfully checked.

The instrument can be placed in the garages, factories to keep a check on temperature data. Thus suitable measures can be taken to monitor the temperature. The limitation of this project is that the sensors which is used for the project is sensitive. One more limitation is that if network is busy, the delivery of SMS may fail.

- Input module design can be made simpler.
- Hardware can be further reduced.
- Data sending can be made real time.
- An alarm can be triggered if the temperature value crosses the limit.
- Better temperature sensors can be used to get accurate values.

### References

- [1] P. Guillemin; P. Friess, "Internet of Things Strategic Research Roadmap", 2009.
- [2] K. Nosbusch, "Industrial IoT in Action", Keynote sessions at Internet of Things world forum, 2013, Barcelona Spain.
- [3] J. Chambers, "Industrial IoT in Action", Keynote sessions at Internet of Things world forum, 2013, Barcelona Spain.
- [4] K.A. Karini, "The IoT architecture needed to enable > 95% of sensing nodes at the edge of the network, Keynote sessions at Internet of Things world forum, 2013, Barcelona Spain.



Mr. Naveen N - received my B.E degree in Computer Science & Engineering from Vishweshwaraiah Technological University, Belagavi, and Karnataka, India in 2016 and received M.Tech degree in Computer Science & Engineering from Dr.Ambedkar Institute of Technology affiliated to Vishweshwaraiah Technological University in the year 2018. He is a teaching assistance, lecturer. He is

working as lecturer, department of computer science & Engineering in Government Polytechnic, Chintamani, and Karnataka, India from the year 2018. He is interested on latest technologies such as Internet of Things, Cloud Computing, Wireless Sensor Networks, Artificial Intelligence etc.



Ms. Lakshmi M A- a student pursuing her studies in 6th semester diploma of Engineering in computer Science & Engineering at Government Polytechnic, Chintamani, and Karnataka Affiliated to Directorate of Technical Education, Bangalore, and Karnataka, India. She has received Secondary School Living Certificate from Karnataka Secondary Education Examination Board in the year 2017.

She has joined to diploma of Engineering in Computer Science & Engineering at Government Polytechnic, Chintamani in the year 2017. She is interested on latest technologies such as Internet of Things, Cloud Computing, Wireless Sensor Networks, Green Computing, Network Security etc.



Mr. Gajendra M- a student pursuing his studies in 4th semester diploma of Engineering in computer Science & Engineering at Government Polytechnic, Chintamani, Karnataka Affiliated to Directorate of Technical Education, Bangalore, and Karnataka, India. He has received Secondary School Living Certificate from Karnataka Secondary Education Examination Board in the year 2015. He has joined to diploma of Engineering

in Computer Science & Engineering at Government Polytechnic, Chintamani in the year 2018. He is interested on latest technologies such as Internet of Things, Android Technology, Wireless Sensor Networks, Network Security, Developing Games etc.



Mr. Naveen N- a student pursuing his studies in 6th semester diploma of Engineering in computer Science & Engineering at Government Polytechnic, Chintamani, Karnataka Affiliated to Directorate of Technical Education, Bangalore, and Karnataka, India. He has received Secondary School Living Certificate from Karnataka Secondary Education Examination Board in the year 2017.

He has joined to diploma of Engineering in Computer Science & Engineering at Government Polytechnic, Chintamani in the year 2017. He is interested on latest technologies such as Internet of Things, Wireless Sensor Networks, and Network Security etc.